



ITEM	SPECIFICATION	
Size	16' (5m)	25' (7.5m)
Height	11' 10" (3.6m)	16' 5" (5m)
Clearance	8' 6" (2.6m)	12' 2" (3.7m)
Frame Weight	88lb (40kg)	110lb (50kg)
Polyester Roof Weight	15lb (7kg)	30lb (13.5kg)
Foot Plates Weight (Total)	44lb (20kg)	44lb (20kg)
Main Profile	1 1/4" (32mm x 2mm)	
Material	Anodized Aluminum / Galvanized Steel	
Fabric	Plain 500D PVC Coated Polyester	
Plain / Printed	Printed 600D PU Coated Polyester	
Nuts & Bolts	Stainless Steel	
Foot Plate	1' (300mm) Stainless Steel	
Package Includes	Foot Plates, Steel Stakes & PVC Protective Cover	
Manufacturer's Warranty	Frame 3 Years / Polyester Plain & Printed 1 Year	

ADDITIONAL INFORMATION

Arch Tents are another fantastic way to draw attention at any event with their unique design and appearance. Our Arch Tents are available in either 16' or 25'. These structures can be fully custom branded making them the perfect promotional tool. A range of accessories are also available with these tents including awnings and walls.



TECHNICAL DIAGRAMS

16' ARCH

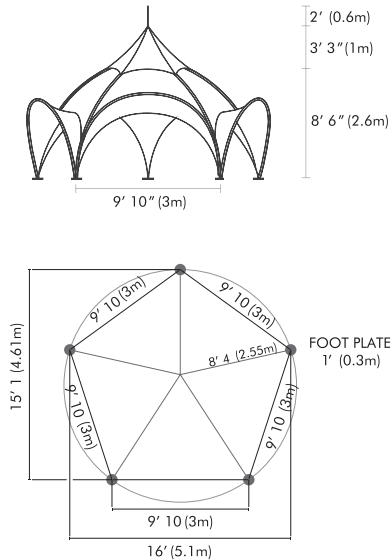

25' ARCH

